

User Manual

RP400/RP500

Thermal Transfer Barcode Printer

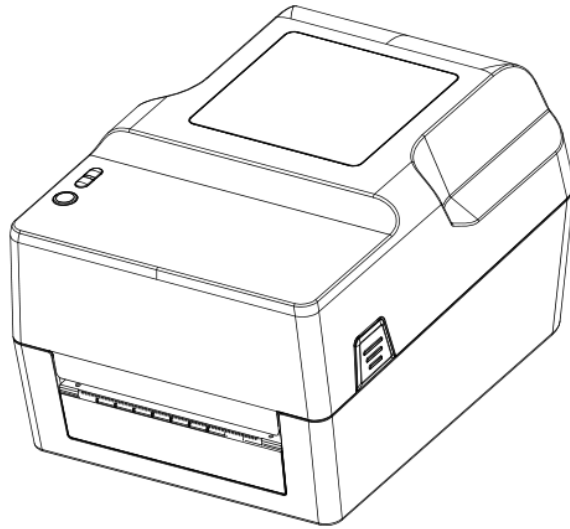

Service hotline: 400-800-0596

Thermal Transfer Barcode Printer

MANUAL

1. Printer profile.....	3
1.1 Introduce.....	3
1.2 Product Feature.....	5
1.2.1 Standard Accessories.....	5
1.2.1 Standard Accessories.....	6
1.3 General specification.	6
1.4 Print specification.....	6
1.5 Ribbon specification.....	7
1.6 Paper specification.....	7
2. Product Introduction.....	7
2.1 Seal of and Inspect.....	7
2.2 Printer Module.....	8
2.2.1 Surface.....	8
2.2.2 Inside.....	9
2.2.3 Bottom.....	10
3. Installation.....	10
3.1 install printer.....	10
3.2 Ribbon installation.....	11
3.3 Paper Installation.....	13
4. The function and LED light and key.....	16
4.1 LED light.....	16
4.3.1 Ribbon detection.....	18
4.3.2 Print Self-test page.....	18
4.3.3 Initialization.....	18
5. Troubleshooting.....	19
5.1 FAQ.....	19
6. Printer simple maintenance.....	22

1. Printer profile

1.1 Introduce

Thanks for choosing our Thermal transfer barcode label printer RP400.

This series machine is equipped with two sets of gear structure of single motor drive can handle 300 meters ribbon belt and using large capacity label paper design collocation. If internal paper size 5' OD (Outer Diameter) capacity can meet, can order outer media holder, outer media holder can support industrial standard 8.4' OD (Outer Diameter) paper capacity.

This printer can meet requirements of real-time and batch label printing via standard Serial, parallel, USB and Ethernet connection port to connect device. This printer can provide thermal printing method or transfer printing. Printer support a wide range of printing paper type, can use of a variety of printing material, including normal paper, thermal paper and folder label paper. In addition, also support common barcode.

This model has been built many common one dimensional code and QR code. Support 4 print directions in different angles. By magnifying the function, the font can enlarge 1-10 times. Besides can zoom font, also provides five different sizes of alphanumeric figure (bitmap font), OCR - A and OCR - B type. Integration with powerful features, competitive price, excellent printing quality, this printer will be the best choice for you in the same level of thermal transfer label printer.

Please refer to the label editing software manual when you use printer to print barcode label. If you need to write introduction program, please refer to the Instruction manual programming, you can copy the instruction manual in accompany CD or download introduction manual in website.

●scope of application

■Manufacturing and warehousing logistics industry

- ◆Manufacturing marking label
- ◆Inventory management labels
- ◆Item labeled tags

- ◆Operating instructions label

- ◆Distribution of instructions label

- medical industry

- ◆The patient labeling

- ◆off-label use

- ◆The specimen label

- parcel post

- ◆Send and signed label

- Small office and studio

- retail industry

- ◆labeled price

- ◆Shelf item label

- ◆Jewelry product label

1.2 Product Feature

1.2.1 Standard Accessories

Product standard accessories	203DPI	
Ribbons print	○	
Thermal print	○	
ABS plastic casing	○	
Gap/black mark sensor	○	
The print head open sensor	○	
USB2.0 (full speed) communication interface	○	
8MB SDRAM memory	○	
4MB FLASH memory	○	
Feeding key & LED indicator light	○	
8 kinds of dot matrix English & number inside	○	
Character and barcode can rotate in the direction of the four printed (0, 90, 180, 270degree)	○	
Built inside simplified Chinese, traditional Chinese and Korean fonts used for programming	○	
Printable text, bar code, pictures	○	
Support bar codes		Support picture format
1D Barcode	2D Barcode	BMP, PCX
Code 39 Code 93, ITF, EAN 128, Code 128 subsets A, B, C, Codabar, EAN-8, EAN-13, UPC-A, UPC-E,	QR code	

EAN and UPC 2(5) digits add-on, MSI, MSIC, PLESSEY, CPOST, ITF 14, EAN 14			
---	--	--	--

1.2.1 Standard Accessories

Outboard Support Optional standard configuration

1.3 General specification.

General specification	RP400	RP500
Printer Dimension	223 (W) × 286 (H) × 169 (D)	
Printer weight	2.35KG	
Power	Built-in automatic voltage switching power supply (Input) : AC100-240V (Output) : DC 24V/2.5A	
Environmental conditions	Operate environment: 4~35°C, operating humidity: 10~90%. Store environment: 4~60°C, Store humidity: 15~85%	
interface	single interface (USB), Double interface (Serial+USB): 4interface (Serial+USB+parallel+internet)	

1.4 Print specification

Model	RP400	RP500
Print head dpi	203dpi	300dpi
Print mode	Ribbon/thermal	
Print speed (inch/sec)	2~6inch/s	
Max print width	104mm	108mm
Max print length	2286mm(90")	
pulse excitation	1×108 pulses	
Thermal slice (abrasive resistance)	50km	

1.5 Ribbon specification.

Ribbon outer diameter	Max 67mm
Ribbon length	Max 300m
Ribbon core size	1 inch(25.4mm)
Ribbon width	Max. 110mm
	Min. 30mm
Ribbon rolling up method	Outward rolling

1.6 Paper specification

Model	RP400	RP500
Inner paper roll max outer diameter	127mm(5")OD	
Paper type	Continuous paper, gap paper, fold paper, black label paper	
Paper rolling up method	Print face outward rolling/Print face inner rolling	
Paper width(label backing sheet)	Max 115mm (4.53")	
	Min 20mm (0.78")	
Paper Thickness (label backing sheet)	Max 0.254mm (10mil)	
	Min 0.06mm (10mil)	
Paper core size	25.4mm~38mm (1" ~1.5")	
Label length	10~2286mm (0.39" ~90")	
Gap paper gap height	Min 2mm (0.09")	

2. Product Introduction

2.1 Seal of and Inspect

This printer is specially packed to prevent possible damage during transit. However, in view of the printer in transit is likely to be expected damaged, it's recommended that you check the packaging and printing advice when receive the printer. If there is obvious damage, please contact the selling shop directly and figure out

the nature and degree of damage; Please keep the packing material in order to send the printer.

When you receive the barcode printer, please place it in a clean, stable desktop and open the package carefully.

Check whether the following items are included:

- A barcode printer
- A Install driver CD
- A plug
- One Power adapter
- One USB Signal transmission line (Optional parallel line serial line)
- Ribbon
- paper Roll
- External support, optional.

Please safekeeping printer packaging equipment and materials for future transportation needs; if any shortage or lack of these goods, please contact you buy goods of the customer service department

2.2 Printer Module

2.2.1 Surface

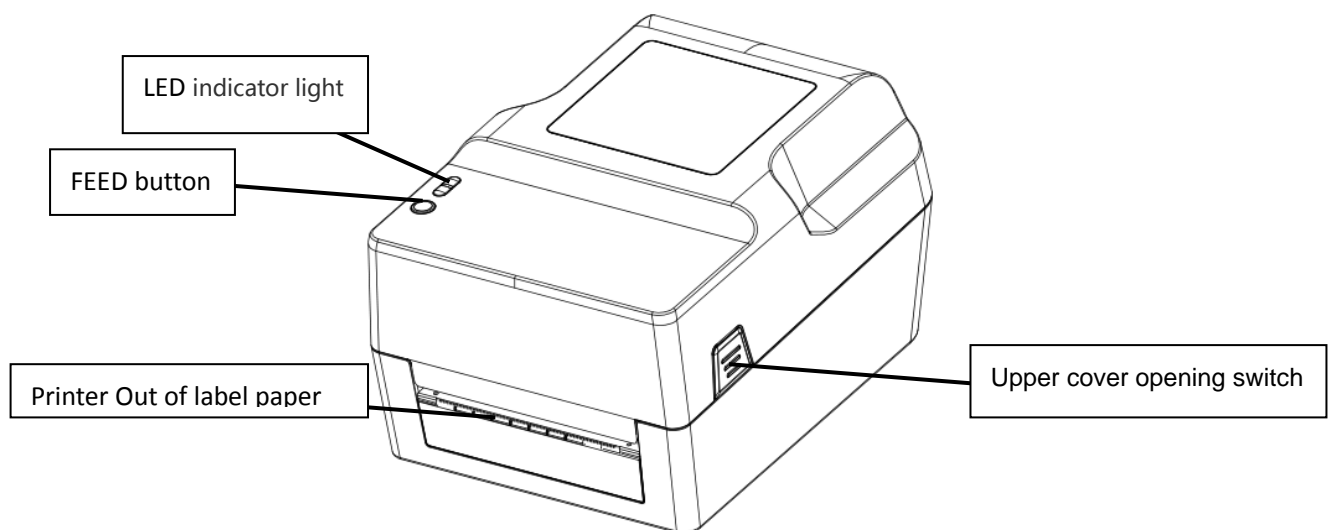

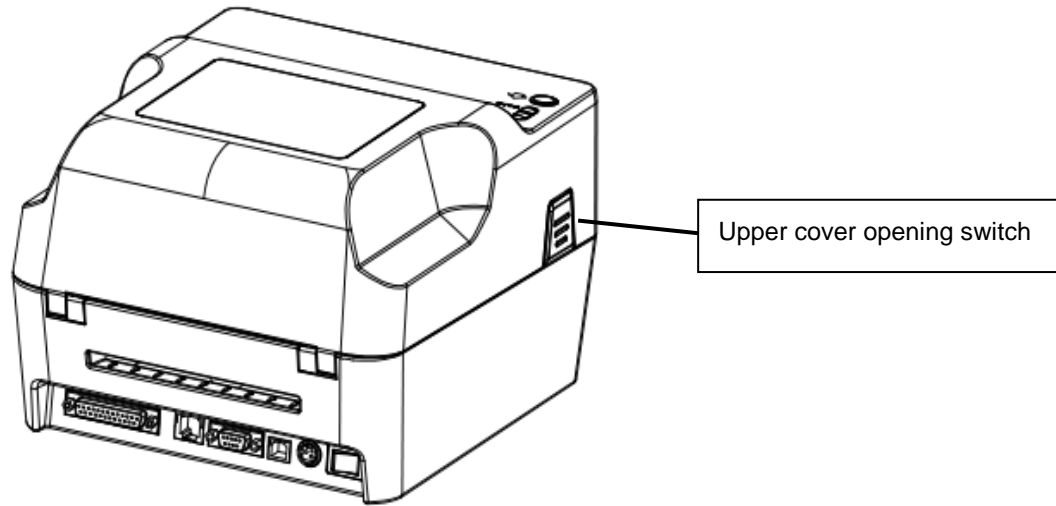

2.2.2 Inside

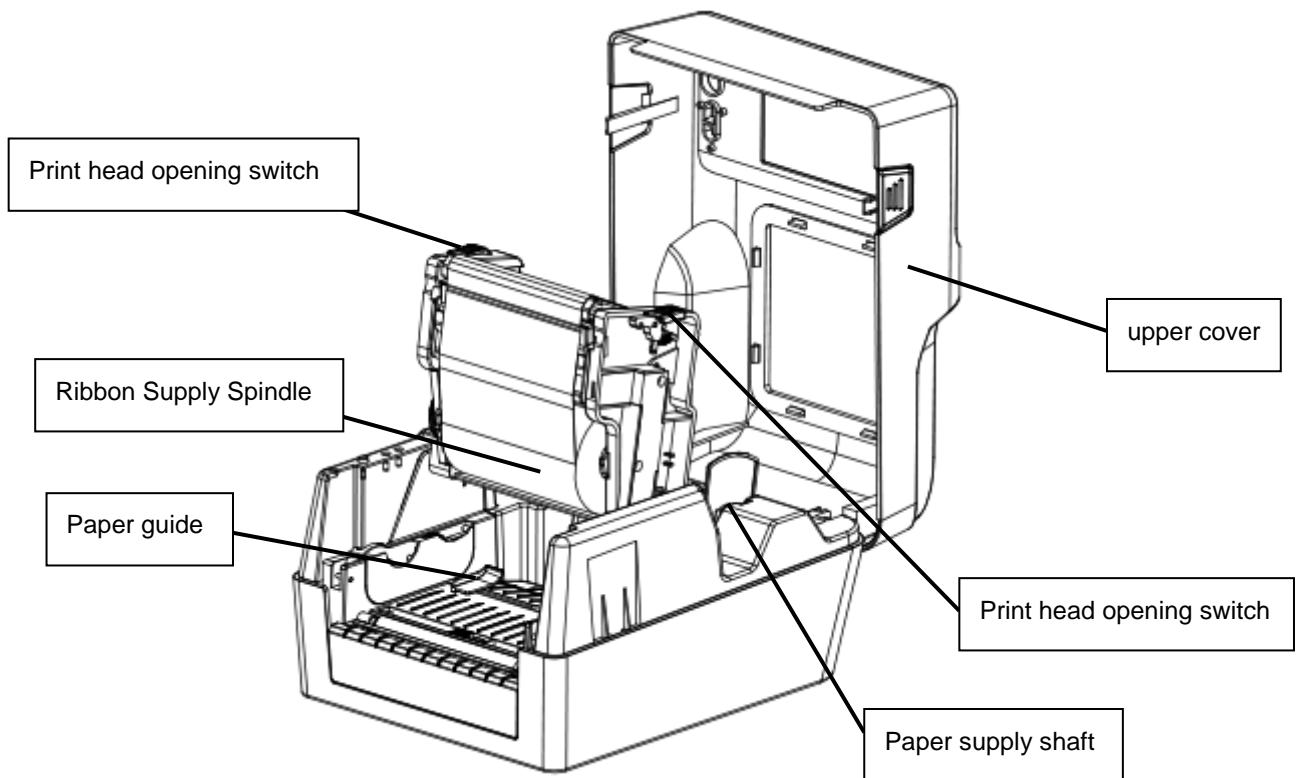

2.2.3 Bottom

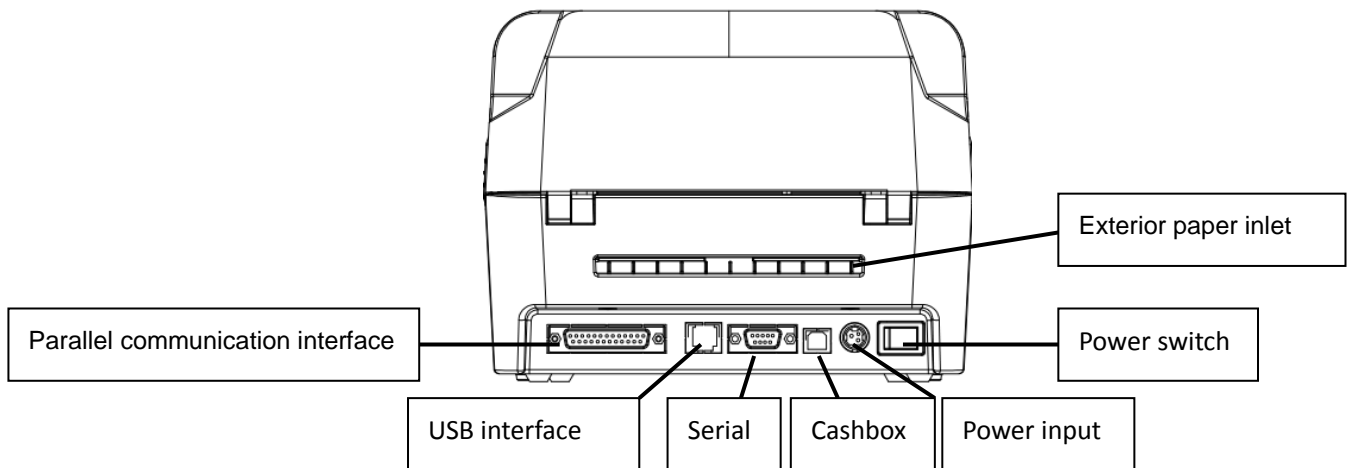

Caution:

As Photos, printer transmission interface will vary according to the difference of your purchased printer's type, the actual transmission interface, please refer to the corresponding product specifications

3. Installation

3.1 install printer

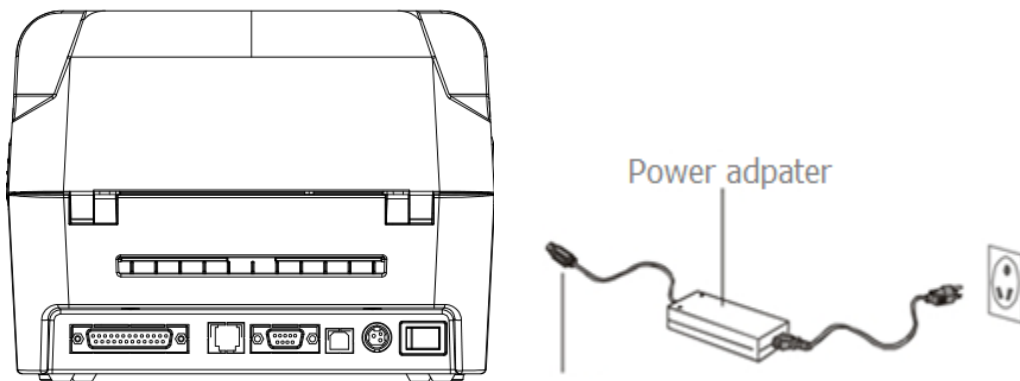

1. Place the printer on a smooth surface.
2. Confirm that the power is off.
3. The end of the serial cable or USB cable insertion slot behind the printer, and make the power supply line interpose to the computer's corresponding of the appropriate slot

4. Plug the power line into the back of the printer, and then plug the other end into the AC outlet.

Caution:

*Please close the printer's power switch, and then insert the power line into the printer's power slot.

*As Photos, printer transmission interface will vary according to the difference of your purchase printer's type, the actual transmission interface, please refer to the corresponding product specifications

3.2 Ribbon installation

1. Push the switch on the left and right sides of the upper cover, and open the upper cover of the printer.



2. Set the empty scroll into the ribbon recovery shaft



3. Make the left side of recovery shaft (Hexagonal side) pressed into the ribbon recovery wheel,

and then assembles the right side

4. Press the print head switch to open the print head
5. Make the ribbon into the supply shaft
6. Make the left side of supply shaft (Hexagonal side) Press into ribbon supply wheel, and then assemble the right side.
7. Make the ribbon around the print head, flat pasted on the ribbon recovery shaft



8. According to the direction of the arrow rotating ribbon recovery wheel, until the ribbon black areas cover the printing head and tightly ribbon, to make no any folds of the ribbon
9. Press down with both hands as the photo and close the printing head. Make sure the print head is completely closed to ensure the printing quality.



● Paper installation path

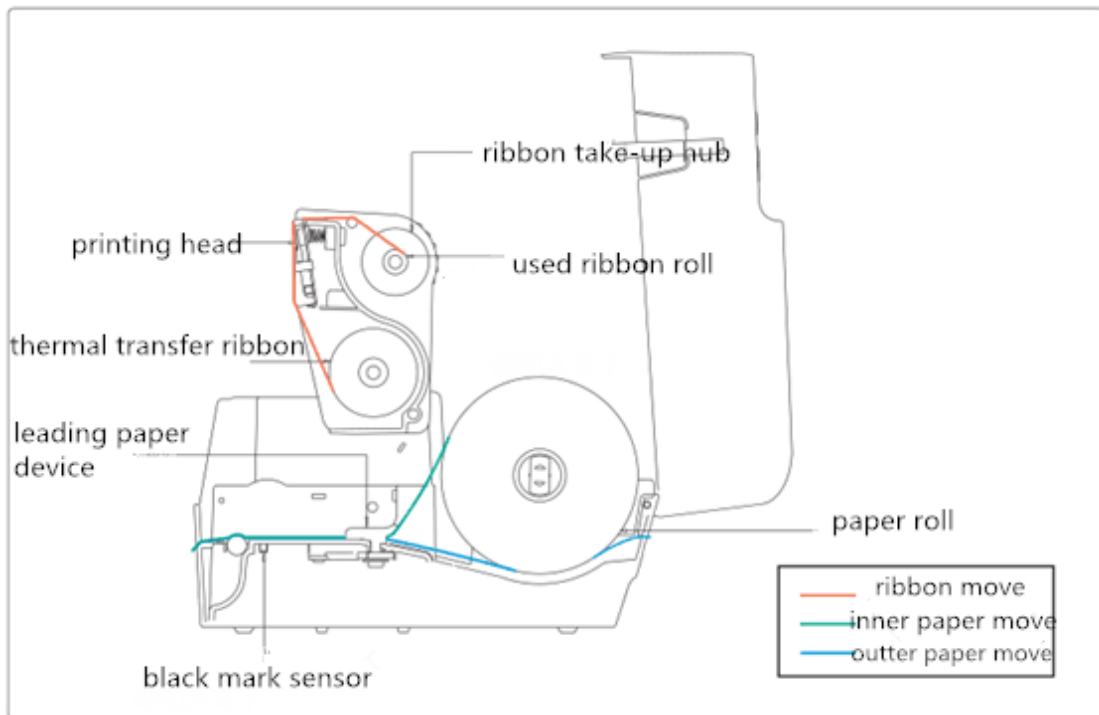

3.3 Paper Installation

1. Push the switch on the left and right sides of the upper cover, and open the upper cover of the printer.



2. Make paper roll into label supply shaft and use stator of paper roll fixed to the central of supply shaft. (If using 3 "wide paper roll, it can remove the stator and use the paper roll directly.)

3. Make the paper placed on the scroll rack

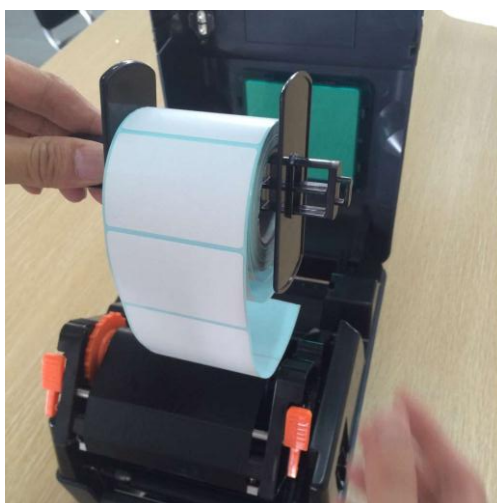

4. Press the printing head switch to open the printing head

5. Pull out the front of the paper (printing side up), through the lower part of the guide bar and the paper sensor, adjust the paper guide same width of paper and slight contact

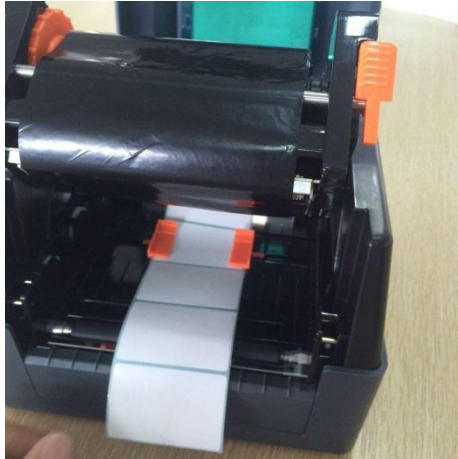

6. With both hands press down as the left arrow's photo, close the print head. Please make sure that the print head is completely closed, to ensure the printing quality.

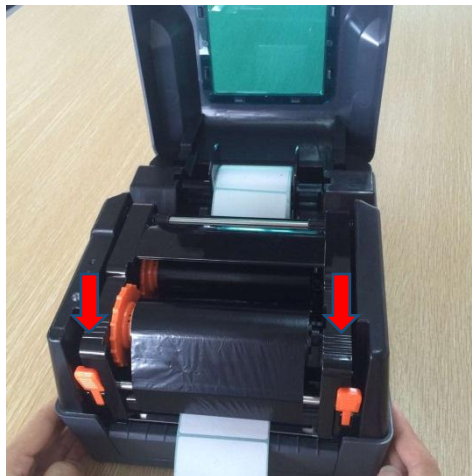

● Paper installation path

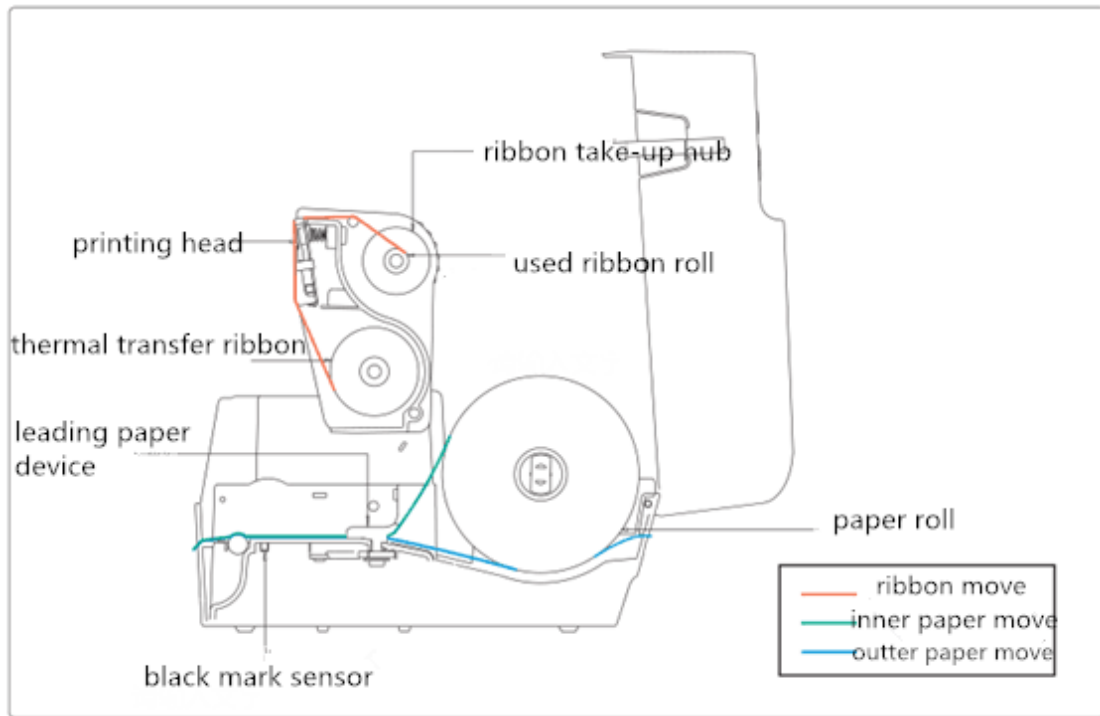

4. The function and LED light and key

The printer has 1 key and 1 indicator. The printer can realize many functions by operating the indicator and the key, e.g. feeding, suspend printing, printing self-test page, initializing printer etc. Hereafter please refer to the following.

4.1 LED light

The LED indication for light and buzzer showed as below:

LED light	Buzzer	Indication
LED light flashes 2 times	Buzzer rings 2 times	Error in mechanism
LED light flashes 3 times	Buzzer rings 3 times	Paper out
LED light flashes 4 times	Buzzer rings 4 times	Error in cutter
LED light flashes 5 times	Buzzer rings 5 times	Overheat
LED light flashes 6 times	Buzzer rings 6 times	Error in opening printer
LED light flashes 7 times	Buzzer rings 7 times	Error in seam mark
LED light flashes 8 times	Buzzer rings 8 times	Error in black mark
LED light flashes 9 times	Buzzer rings 9 times	Failure to find SDRAM
LED light flashes 10 times	Buzzer rings 10 times	Failure to find flash

LED light flashes 11 times	Buzzer rings 11 times	Error in ribbon
----------------------------	-----------------------	-----------------

4.2. General Keys Function

1. Paper Loading

When the printer is ready (blue LED fixed); click on the button, label paper will get in to the front end of next page.

2. Printing Pause

While printing, press the FEED button gently to make printing pause. As long as you press the button again, the printing job is back to normal.

4.3. Power on Function

The printer has three power on functions can be used to set or test printer hardware. Pressing or releasing the button at the same time when turning on the power will activate these features.

Please activate the power-on functions by following steps:

Function:	Instruction:
Power On Self-Test	A. Close the printer power supply. B. Verify the printer has paper loaded and open the printer power supply, then the printer start to print the self- test page, after that release paper loading button.
Printer initialization	A. Close the printer power supply. B. Open the print head cover, and press the FEED button, and then open the printer power, keep pressing FEED button for 10 seconds, the printer will clean the download data in internal memory (DRAM), and the printer parameters restore to factory default Settings.
Ribbon detection & automatic location	In power on station, when you open the cover to replace the paper, the printer will start ribbon detection and automatic location

4.3.1 Ribbon detection

This function is available in thermal transfer model. It's for ribbon conditions detection.

4.3.2 Print Self-test page

This function is about exam and show the setting data, which is used to judge if the printer is on good working condition.

Please follow below steps to check if the label is in right position:

1. Please confirm the paper is well set up.
2. Turn off the power
3. Press the FEED button and turn on the power
4. When the printer start printing, loosen the FEED button
5. The page printed our is the self-test page

■Self-test page model

Before connecting to PC, we can print the self-test page to confirm the condition if the printer. The page can be used to test the printer head and showed the setting data of the printer.

4.3.3 Initialization

Initialization means to clear up the DRAM memory and initialize the printer to factory settings.

Please follow below steps to initialize the printer

1. Turn off the power.
2. Open the cover and press the FEED button and then turn off the power and keep pressing the FEED button for 10s.
3. When all the light is off, loosen the FEED button. The printer will restart itself and finish the Initialization.

After Initialization, the settings should be as below,

Printer head pressure should be adjustable. You can adjust the pressure in two levels under the ribbon recover axle. Please remember to keep the gears in same level, or it will badly affect the printing quality.

5. Troubleshooting

5.1 FAQ

The contents in following table are the frequently asked questions and solutions: please kindly contact the vendor for further assistance, if the printer still not workable under your proper operation to clear faults corresponding to our brief guide.

Problem	Reason	Solution
Power indication light fault	<ul style="list-style-type: none"> ● Incorrect plug connection between alternative socket, power supply and the printer ● Printer power switch off 	<ul style="list-style-type: none"> ● Ensure correct plug connection between alternative socket, power supply and the printer ● Keep printer power switch on
	<ul style="list-style-type: none"> ● Carbon ribbon runs out ● Incorrect installation of carbon ribbon 	<ul style="list-style-type: none"> ● Install carbon ribbon ● Re-install the carbon ribbon corresponding to the instruction guide
	<ul style="list-style-type: none"> ● Label paper roll runs out ● Incorrect installation of label paper roll 	<ul style="list-style-type: none"> ● Install the label paper roll ● Re-install the label paper roll corresponding to the instruction guide ● Re-adjust the dimension and print
	<ul style="list-style-type: none"> ● Space sensor detection error ● Label paper stuck up 	<ul style="list-style-type: none"> ● Re set the dimension and print ● Clear inner parts
Printing fault	<ul style="list-style-type: none"> ● cable connection error between interfaces ● Serial cable pins non-one to one type 	<ul style="list-style-type: none"> ● Re-connect the cables ● If use serial cable: <ul style="list-style-type: none"> -Adopt serial cable and ensure pins to be one-to-one type -Confirm the serial port data transmission rate by self-test

		<p>page</p> <ul style="list-style-type: none"> ● If use Ethernet cable (Ethernet), -Ensure light Ethernet RJ-45 green/orange on -Ensure the printer obtains IP under DHCP mode -Please make sure when using the fixed IP to set IP add. IP Address Setting is correct -Please wait a moment for printer connecting with server, then check the IP add. Again. ● Replaced with new transmission lines ● ribbon and tags do not match ● Verify that the ink ribbon surface is installed correctly ● Reinstall the ribbon ● clean the printer head ● Printer print density setting is incorrect ● Poor contact of printer head connector, please turn off power, and reseal printer head connector ● Make sure the motor connector is connected properly
<p>Poor print quality</p>	<ul style="list-style-type: none"> ● Ribbons and labels are not installed correctly 	<ul style="list-style-type: none"> ● Reinstall consumable ● clean printer head

	<ul style="list-style-type: none"> ●Accumulation of dust on the print head or adhesives ●Printer print density setting is incorrect ●The print head is damaged ●ribbon and tags do not match 	<ul style="list-style-type: none"> ●Clean the rubber rollers ●Adjust the printer print density and print speed ●Print out self-test page to check whether is printer head damage or not, if yes, please replace the printer head ●Replace suitable ribbon and label paper ●Thickness of the label paper more than 0.22mm, may cause print quality is not good enough ●Make sure that printer head seat frame is completely closed
Paper jump while printing	<ul style="list-style-type: none"> ●label size is not correct or incomplete ●After changed the label paper, no correcting the sensor ●Label sensor is covered with dust cause detect incorrect 	<ul style="list-style-type: none"> ●resize and printing ●Using air brush to clean the dust on the sensor

Printer content is lost on left and right side	<ul style="list-style-type: none"> ●Wrong label size 	<ul style="list-style-type: none"> ●Set correct label size
Label paper fold	<ul style="list-style-type: none"> ●print head pressure uneven ●wrong installation of ribbon ●wrong installation on label ●wrong print density ●wrong label feed 	<ul style="list-style-type: none"> ●set correct print density ●adjust suitable label width
Black label paper	<ul style="list-style-type: none"> ●Print head dirty 	<ul style="list-style-type: none"> ●clean print head

appear gray lines	●Rubber roller dirty	●clean rubber roller
Unstable printing	●Set printer under Hex Dump mode ●Set RS232 communication wrong	●Re-start printer, jump out of dump mode ●re-set RS232

6. Printer simple maintenance

For this simple maintenance program to ensure print quality, can prolong the printer life, the following are some maintenance we suggest:

1. Please use the tools listed below to clean and maintain your printer:

- Cotton swab
- Cotton cloth
- Dust cleaner or air-brusher
- 100% alcohol(industrial alcohol)

2. Cleaning and maintenance procedures:

Cleaning parts	steps	Suggested cleaning frequency
Print head	1. Please turn off printer 2. cool print head at least one minute 3. Use cotton swab to wipe print head surface with 100% alcohol	When replace a new label paper roll.

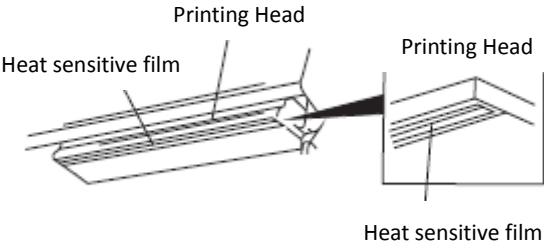
	Thermal slice printer head	
	 <p>The diagram illustrates the components of a thermal slice printer head. It shows a 'Printing Head' on the left and a 'Heat sensitive film' on the right. A 'Printing Head' is also shown on the right, with a 'Heat sensitive film' below it. A line connects the two printing heads, indicating the path of the film.</p>	
rubber roller	1. Turn off the printer power 2. Wipe 100% alcohol using cotton cloth or cotton swab	When changing label paper
Paper tearing	Wipe 100% alcohol using cotton cloth	When it is necessary
sensor	Sweep the dust on the sensor using air-brush or dust collector	Every month
Machine interior	Sweep the dust inside the machine using air-brush or dust collector	When it is necessary

Note:

1 never touches the thermal slice by hand directly. Wipe the thermal slice using 100% alcohol if it is touched by accident.

2 using industrial alcohol. Never use medical alcohol, which may damage the thermal slice.